

# CONEN<sup>®</sup> mounts

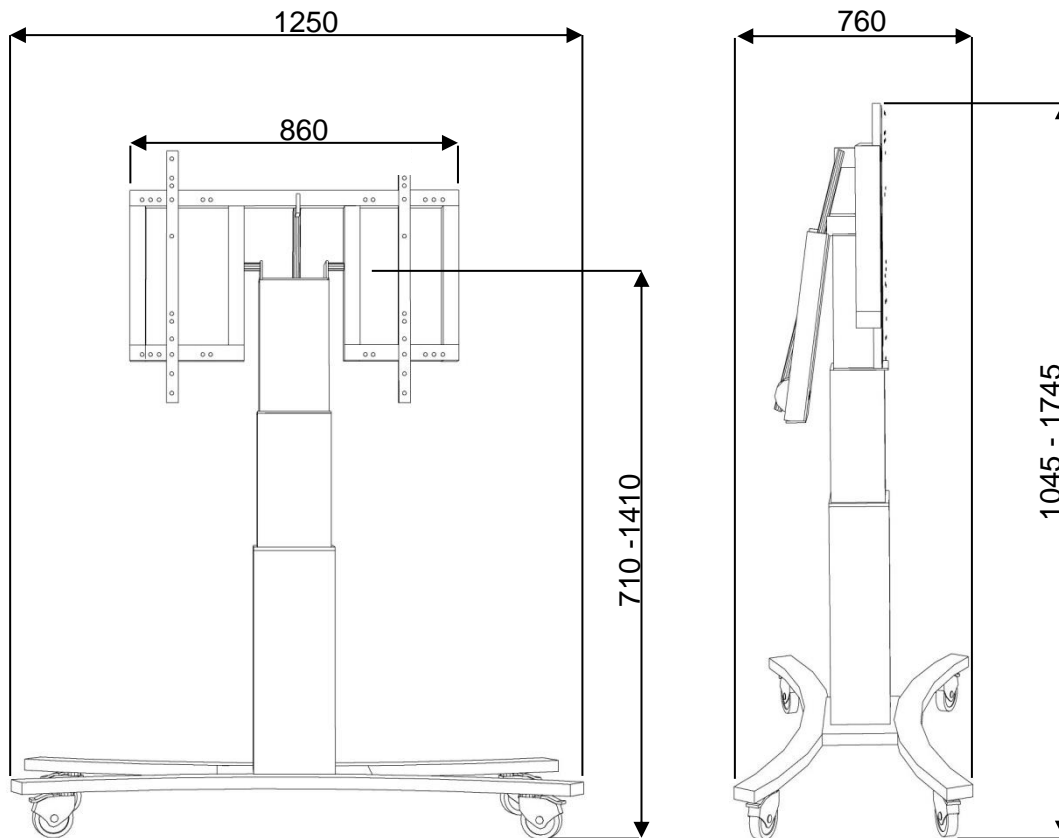

Short product description	Electrical height adjustable and tiltable mobile system for kindergarden, primary and secondary school and for grown-ups
Item no.	<b>SCETTAC3535</b>
Product features	<ul style="list-style-type: none"> <li>- electrical height adjustable and tiltable column</li> <li>- 700mm stroke, 90° tilt</li> <li>- mobile stand, C-shape, RAL 9006</li> <li>- color white aluminum</li> <li>- frame for use with 42" - 84" displays</li> </ul>
Units	mm
Maximum load	> 120kg
Net system weight	approximately 56kg

Packing units	CCET353 5	AFSCETT A	MSTSCET AC
Short description of packing units	Motorized center column, L=585mm	Universal frame with electrical tilt feature for displays	Mobile stand, C-shape
Packing dimensions: height x width x depth (mm)	820 x 270 x 220	890 x 770 x 480	1350 x 780 x 120
Gross weight (kilograms)	24	26,8	15,5
Net weight (kilograms)	20,8	22,1	12,8

