

Andromeda presentation stands

Andromeda stands are a flexible AV solution that can be either permanently installed, or specified as a mobile resource for use in a number of different meeting spaces. They are based on a narrow column chassis design and offered as a presentation model, or equipped with camera and speaker mounts for collaboration use.

In its simplest form, the Andromeda design accommodates a single screen from 32 in. up to 55 in., or can be equipped for twin 46 in. screens. As an option, single screens can be rotated through 90 degrees and a media player installed in the 2U rack space, transforming the stand into a digital signage player. A choice of bases and finishes ensures that the requirements of most customers can be met.

With so many variations, it would be impossible to show them all, so here is a small sample of what can be achieved using a standard set of components.

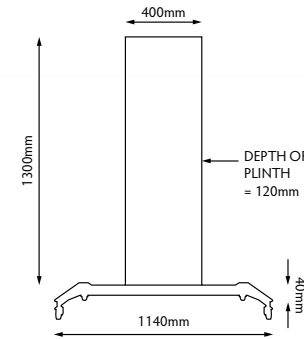

Key features

- Easy to deploy and re-deploy
- Ergonomic design
- Not limited to screen vendors, resolution or technology
- Single or dual screen (upgradable)
- Portrait screen option (single screen only)
- 2U X 2 integral equipment space
- Integrated cable ties and cable tidy
- Serviceable from the front
- Choice of colours and finishes
- Multipoint/height mount
- 12 month warranty



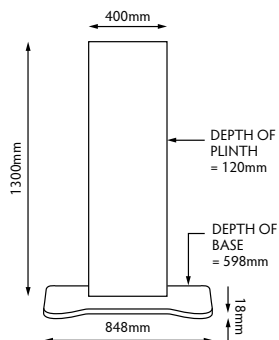

Options

- Single or twin screen mount
- Fixed or mobile base options
- Mono speaker bar: bottom of screen*
- Choice of colours: Black, White and Silver
- Custom colours on application
- Camera mount: top or bottom
- External shelf
- Internal rack shelves
- Lock for front panel
- Choice of castors – lockable, small, medium and large
- Personalisation – ‘your logo here’



AN02



AN04

Ordering information – Andromeda presentation stands

DESCRIPTION	CODE
Andromeda stand with single screen mount and base with castors	AN01
Andromeda stand with double screen mount and base with castors	AN06
Andromeda stand with single screen mount and fixed base	AN02
Andromeda stand with double screen mount and fixed base	AN04

N.B. screens, cameras and speakers are not supplied but shown for illustrative purposes only.



* Speakers not provided.

Andromeda collaboration stands



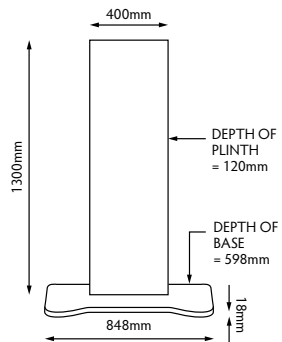
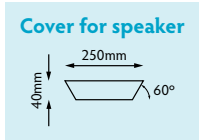

Ordering information – Andromeda collaboration stands

DESCRIPTION	CODE
Andromeda stand with single screen mount, camera mount and base with castors	AN09
Andromeda stand with double screen mount, camera mount and base with castors	AN14
Andromeda stand with single screen mount, camera mount and fixed base	AN10
Andromeda stand with double screen mount, camera mount and fixed base	AN12

N.B. screens, cameras and speakers are not supplied but shown for illustrative purposes only.

Aquila presentation and collaboration stands

Aquila stands are based on a wide column/chassis design suited to use in medium and medium-large meeting spaces, where groups of up to 15 people want to present and exchange ideas, collaborate between offices, or simply create an executive space that enhances the meeting experience. They are also ideal for use in lecture halls, reception areas, atriums and at exhibitions.

Due to their size and weight, Aquila stands are usually permanently installed, although small castors can be incorporated in the base to facilitate minimal movement. The stands will hold a single screen from 55" up to the latest 80" models or, optionally, two 65" screens can be fitted to create a consummate presentation and video conferencing solution.

As an option, single screens mounted on an Aquila stand can be orientated to portrait, to create a digital easel when using a touch screen. Utilising the wide 2U X 2 rack space, Aquila will accommodate a media player, codec, amplifier or even a digital TV receiver, enabling the stand to be used as digital signage player, TV, or group collaboration device. The collaboration version includes camera mount and a wide stereo speaker bar.

A range of options, bases and finishes ensures the needs of every customer can be met, even down to displaying the organisation's logo on the front of the stand. With no limits to the screen vendor, resolution, size or orientation, Aquila sets new standards in executive stands for versatility, quality and price.

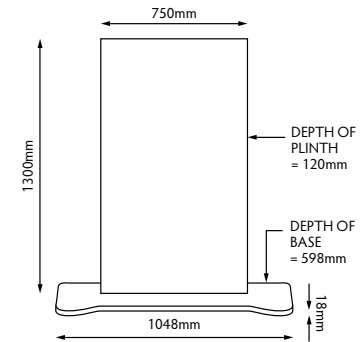

Key features

- Options for one or two screens
- Portrait screen option (single screen only)
- Not limited to certain screen vendors or technology
- UHD and touch screen ready
- Wide 2U X 2 integral equipment space
- Additional storage base option
- Integrated cable ties and cable tidy
- Lockable front panel for easy servicing
- Camera mount options
- Stereo speaker bar mounted at top or bottom of screen*
- Multi-point/height mount
- Hardware venting
- Lifetime warranty



* Speakers not provided.

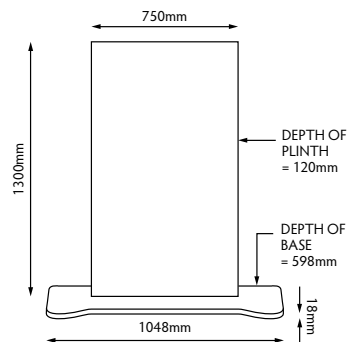

Options

- Universal mount for single screen from 55" to 80"
- Dual screen mount for screens up to 65"
- Mobile or fixed installation with a choice of bases:
 - Low profile
 - Storage or equipment
 - Slim line for close to wall installations
 - Small castor version (minimal movement only)
- Universal equipment mount for codecs and other AV equipment
- Choice of standard colours: Silver, Black and Classic White
- Optional colours and highlights available to customers' specification

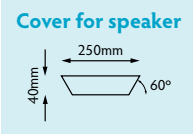

AQ07



AQ09

Ordering information – Aquila presentation and collaboration stands

DESCRIPTION	CODE
Aquila stand with single screen mount and base with castors	AQ01
Aquila stand with double screen mount and base with castors	AQ03
Aquila stand with single screen mount, camera mount and fixed base	AQ07
Aquila stand with double screen mount, camera mount and fixed base	AQ09

N.B. screens, cameras and speakers are not supplied but shown for illustrative purposes only.

